

Cleartrap CLS 125, 200, 300



CLS 125

Description

The Bosch Cleartrap Liquid Separator is designed to help prevent liquid water (not water vapor) and large solids from entering a vacuum pump which could cause corrosion, premature wear or damage. Common applications include meat tumblers, beverage degassing, soil remediation, and vacuum sewers.

Features

- Clear plexiglass housing for easy viewing
- Water compatible materials
 - Plexiglass housing
 - Stainless steel pipe connections
 - Polyethylene endcaps
 - Brass drain valve
- Ball Float for emergency shut off
- 60 mesh (250 microns) screen
- Drain valve
- Vacuum gauge
- Options available

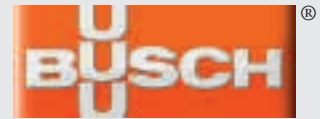

Operating Principle

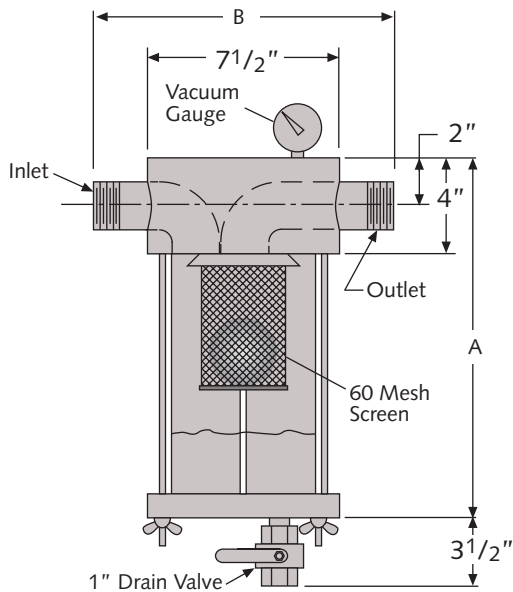

Air with liquids and large solids enters the top of the separator and is directed downward into the plexiglass container. The air is then drawn up and exits through the filter screen leaving liquids in the bottom of the container and large solids on the screen. Trapped liquid should be drained when it reaches the marker on the separator. A plastic float ball located inside of the screen prevents liquid from being sucked into the vacuum pump by shutting off flow if the liquid rises above its maximum operating level. The ball can be removed for applications that produce large air surges that could cause a nuisance shut-off. In such cases, the liquid level can be checked by visual inspection or an optional liquid level sensor. Wing nuts on the separator container allow easy disassembly for cleaning.

Dimensions	A	B	Pipe Connection	CFM
CLS125	15 1/2	10 1/2	1 1/4" NPT	100
CLS200	15 1/2	11 1/4	2" NPT	250
CLS300	16 1/2	11 1/4	3" NPT	500

All dimensions in inches unless otherwise noted.



Busch - all over the world in industry

ISO 9001 Registered Company

**Busch, Inc. 516 Viking Drive Virginia Beach, VA 23452
Phone (757) 463-7800 FAX (757) 463-7407**

**www.buschpump.com
1-800-USA-PUMP**

Amsterdam Barcelona Birmingham Basel Brussels Dublin Göteborg Helsinki Istanbul Copenhagen Kuala Lumpur Milan Maulburg Melbourne Montreal Moscow
New York New Plymouth Oslo Paris San Jose São Paulo Seoul Singapore Taipei Tokyo Vienna